

**c.p. bourg**®



# Perfect Binding, Think Smarter

## Fast In-Line and fully automatic high-quality book production.

The solution automates the binding process, minimizes labor requirements, and eliminates waste. It is the best way to optimize asset utilization for diverse and short-run job streams production. The quality of the end-product is outstanding and the binding result is always precise and identical.

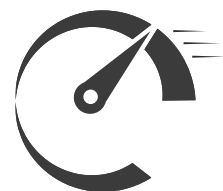

## Great connectability with digital printers.

Ultra-modular, the Bourg Perfect Binding Solution is tailored to adapt to your needs. We offer an end-to-end solution connectable to Canon, Ricoh and Xerox printers: just load white paper and collect the finished books ready for distribution.

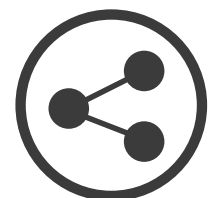

# PRODUCTION WORKFLOW



Our Perfect Binding Solution is bi-directional and modular, works In-Line, Off-Line and in Dual-Mode.

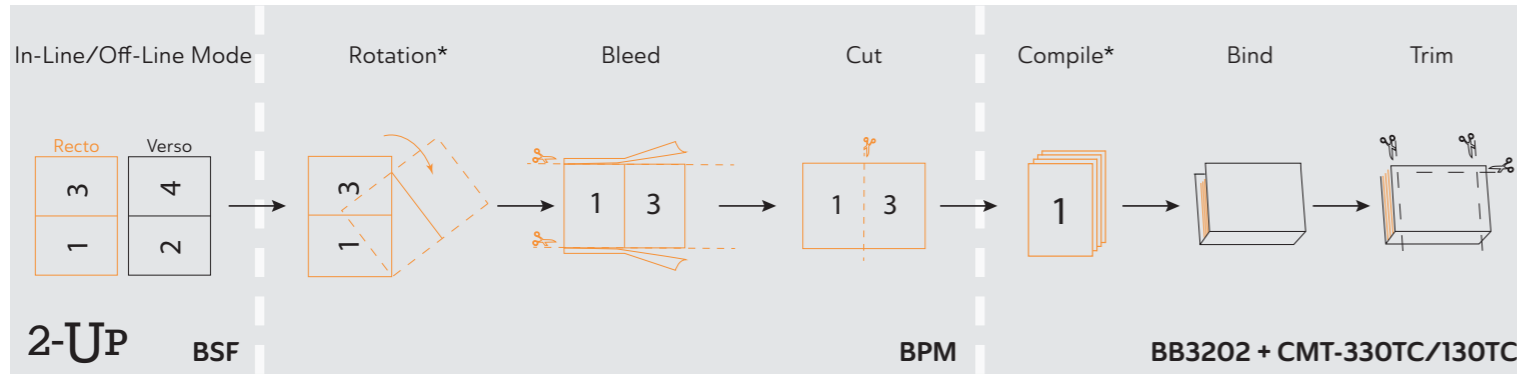

# FINAL APPLICATIONS

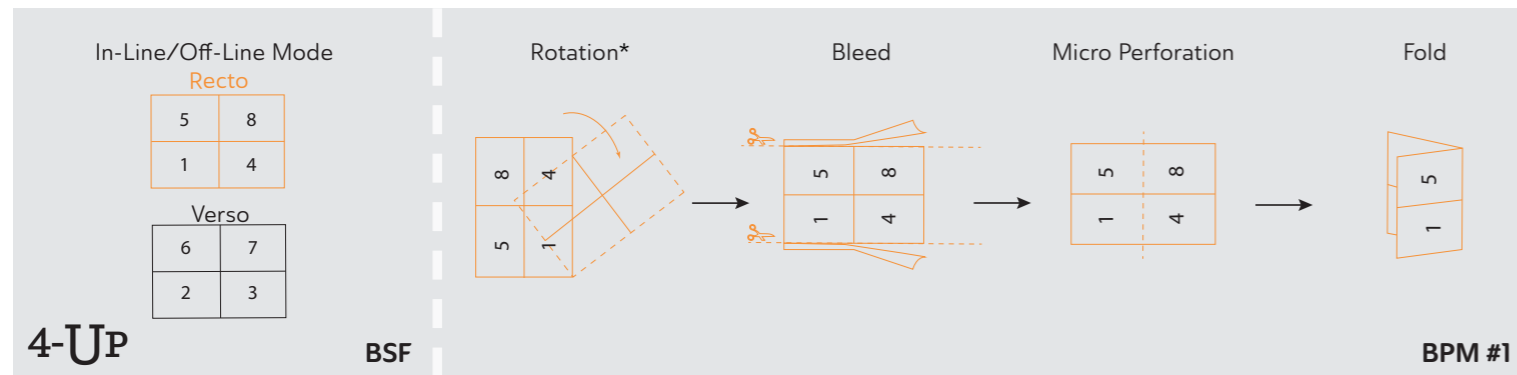
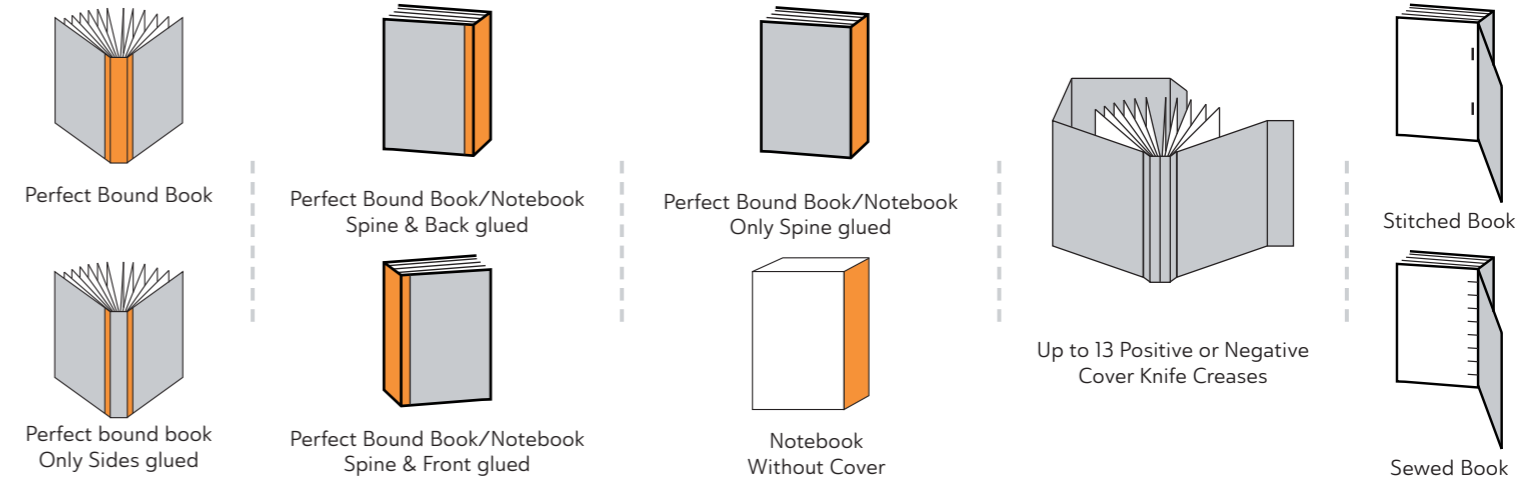

\* Our Perfect Binding Solution compiles stacks from page 1 to N or page N to 1.

# DIMENSIONS

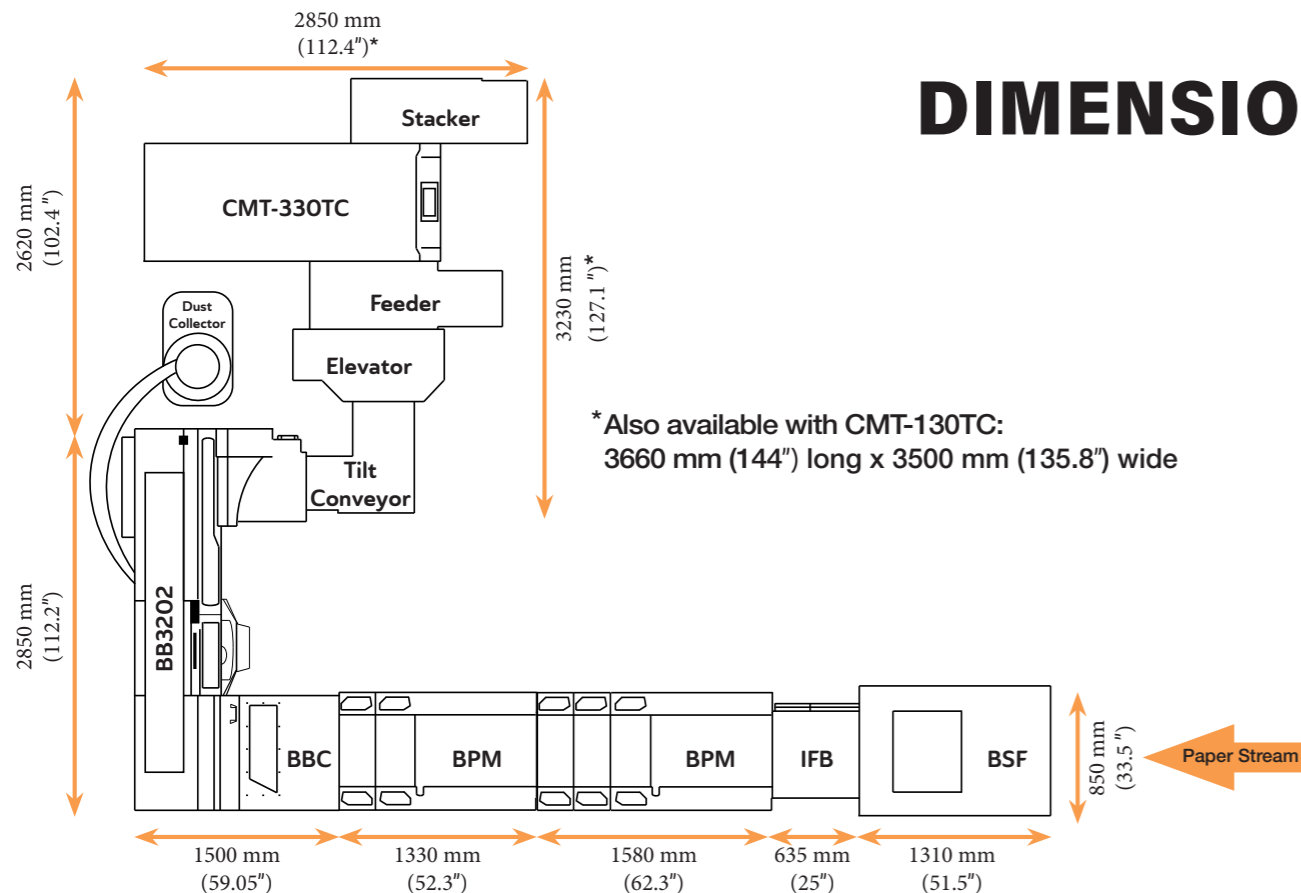

# TECHNICAL SPECIFICATIONS

## Perfect Binding Mode

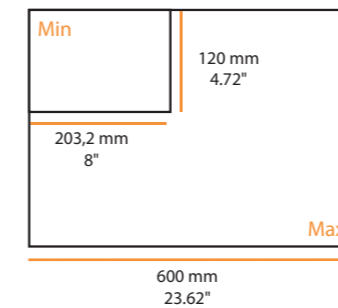

## Padding Mode\*

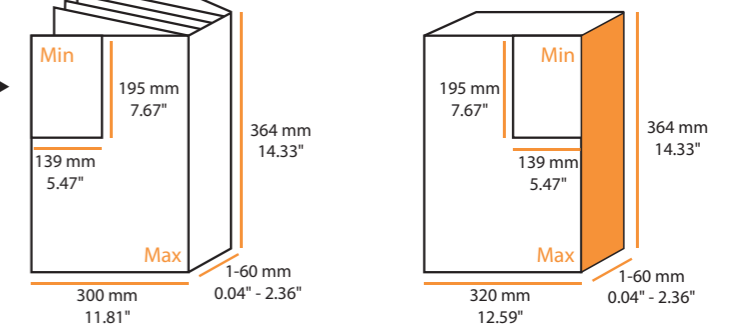

\* Padding mode is not available with PUR version due to cure time

Maximum productivity	Off-Line	650 cycles/hour
	In-Line	In-Line digital printer speed
Cover format	Minimum	100 x 180 mm (3.93 x 7.08 in)
	Maximum	385 x 750 mm (15.15 x 29.52 in)
Paper Weight	Media	60 to 200 gsm
	Cover	80 to 300 gsm
*Rotation format	Minimum	139 x 170 mm (5.5 x 6.7 in)
	Maximum	300 x 370 mm (11.8 x 14.5 in)
Milling depth		0 to 3 mm (0 to 0.11 in)



VISIT  
www.cpbourg.com  
f in t

# YOUR PERFECT BINDING SOLUTION

The Bourg Perfect Binder BB3202 EVA/PUR-C is the only perfect binder designed to operate In-Line & Off-Line with digital printers. It is designed to create state-of-the-art perfect bound books for the Book On-Demand market. The integrated book thickness detector automatically adjust the machine set-up while jogging to process each book most productively.

The industry first Bourg Sheet Feeder (BSF) uniquely combines the best of Off-Line & In-Line finishing with its Dual-Mode capability. The BSF brings you perfectly finished jobs, great flexibility, shorter turnaround and maximum productivity without manual intervention.

The Bourg Sheet Preparation Module (BPM) is a fully automated, modular and scalable sheet preparation unit that vastly simplifies the creation of booklets. The BPM revolutionizes and challenges the establishment through innovation.

The CMT-330TC/130TC Trimmer incorporates the most advanced book trimming technology available. It is tailor-made for the fully automated book-of-one trimming environment without performing manual intervention or exchanging clamps. It automatically switches between feeding books directly from the BB3202 EVA/PUR-C or from a manually loaded Near-Line book pile feeder.

## WHAT WE DO BETTER



◆ Book of One or Many.  
In-Line, Off-Line & Dual-mode.

◆ Fully autonomous In-Line Binder:  
Automatic job set-up.



◆ Dynamic knife creasing technology: Up  
to 13 positive or negative cover creases.

◆ Fully automated Book of One  
trimming without manual intervention.



◆ Available in EVA and PUR glue.

◆ PUR Perfect Binder compatible with:  
Both PUR & EVA glues.



◆ Ultra-modular platform:  
1-Up / 2-Up / 4-Up workflows.

◆ Full JDF and XML automation from web  
platform to perfect bound books.

